

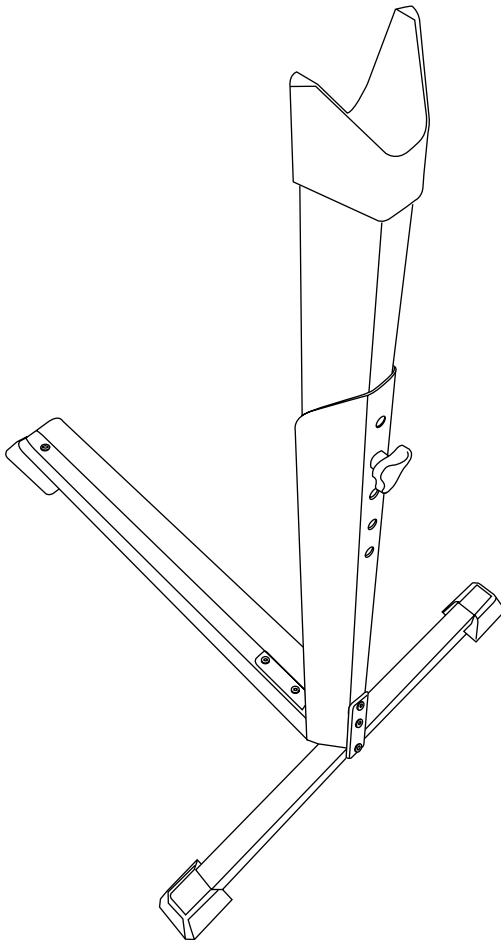

BikeNook™

bicycle stand

Assembly Instructions



THANK YOU

Congratulations on your choice of the Bike Nook™ bicycle stand, the brilliant new way to store your bike away, quickly and easily.

The Bike Nook™ bicycle stand is as easy as 1-2-3 and saves up to 3.5 feet (1 meter) of valuable floor space, and the best part is that it easily adjusts to accommodate most bikes, wheel size 18in/46cm and up.

Please use these easy to follow instructions for tips on how to set up your Bike Nook™ and use it for different sizes of bikes.

We hope you enjoy the quick and easy new way to store your bicycle, and all of the free space you get back!

Thane Direct and its affiliated companies assume no liability for personal injury or property damage resulting from the misuse of the Bike Nook™ bicycle stand including the failure to comply with the instructions contained in this User's Guide.

WHAT YOU GET

1. Cross Bar
2. L-Piece
3. Foot
4. Track
5. Ramp
6. Diamond Bracket
7. Upright
8. Adjustable Upright
9. V-Slot
10. Adjustment Knob
11. Socket Wrench
12. Allen Key
13. Washers
14. Nuts
15. Long Bolt
16. Bolts
17. Flathead Bolt

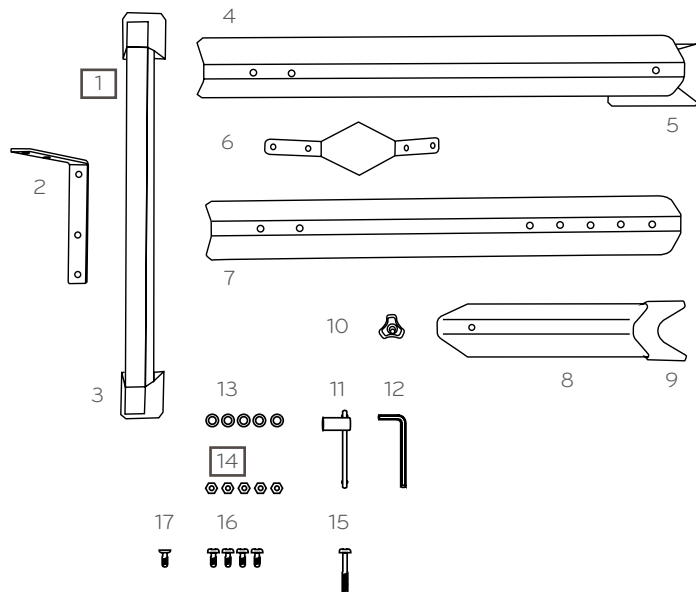

2

STEP 1

Connect L Piece to Cross Bar

Parts Required:

1. Cross Bar
2. L-Piece
3. Foot
11. Socket Wrench
12. Allen Key
13. Washers
14. Nuts
15. Long Bolt
17. Flathead Bolt

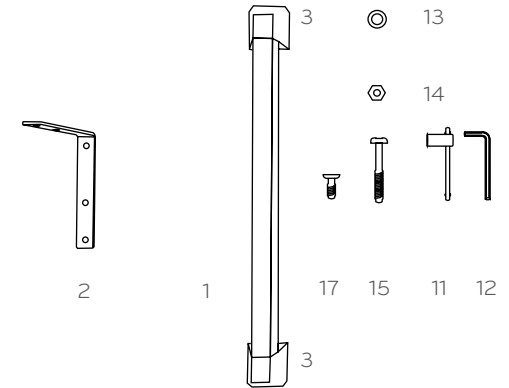

Connect the L-Piece to the Cross Bar by aligning the arrow (↑) on the L Piece to the arrow on the Cross Bar so that both arrows are facing in the same direction

Insert the Flathead Bolt into the L-Piece and tighten using the Allen Key

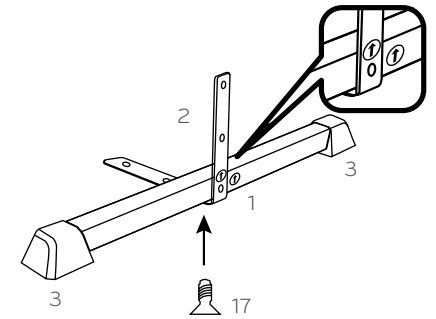

Turn the Cross Bar over so that it is resting on the Feet. Insert the Long Bolt into the bottom hole of the L-Piece

Place a washer, followed by a nut, on the protruding end of the Long Bolt. Secure the Nut to the Long Bolt by using the Socket wrench and Allen Key

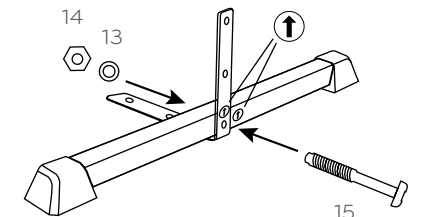

3

STEP 2

Connect the Track to the Cross Bar

- 4. Track
- 5. Ramp
- 6. Diamond Bracket
- 11. Socket Wrench
- 12. Allen Key
- 13. Washers
- 14. Nuts
- 16. Bolts

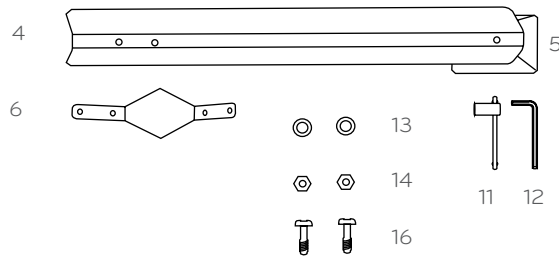

Connect the Track to the Cross Bar by placing the Track on top of the L-Piece. Align the holes on the Track with the holes on the L-Piece

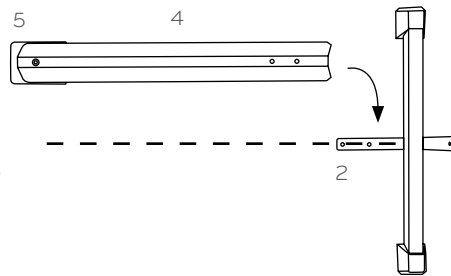

Place the Diamond Bracket on top of the Track so that the holes in the Diamond Bracket are aligned with the holes in the Track and the holes in the L-Bracket

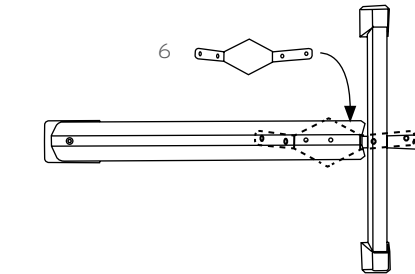

Place a Bolt from the underside of the L-Piece through the corresponding holes in the L-Piece, Track and Diamond Bracket, so that the bolt end protrudes through the Diamond Bracket. Place a Washer and Nut on the protruding section of the Bolt and tighten using the Allen Key and Socket Wrench. Repeat for second hole.

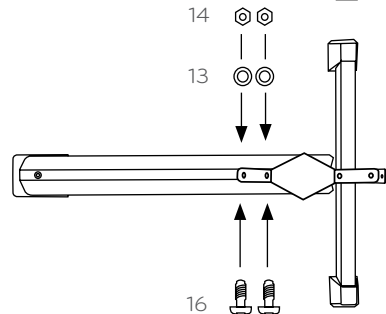

The Track should now be secured to the Cross Bar by 2 bolts.

Note: The Diamond Bracket and L-Bracket should be parallel to one another with a gap between them

4

STEP 3

Connect the Upright to the Cross Bar

- 7. Upright
- 11. Socket Wrench
- 12. Allen Key
- 13. Washers
- 14. Nuts
- 16. Bolts

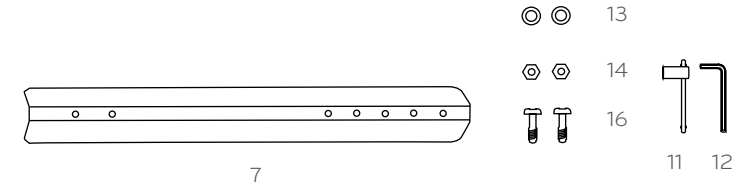

Place the Upright in-between the gap between the Diamond Bracket and the L-Piece

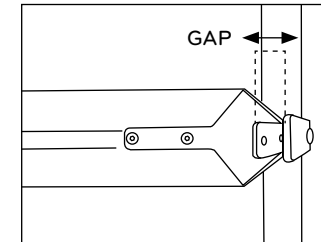

Ensure the holes of the Diamond Bracket, the Upright and the L-Piece are aligned

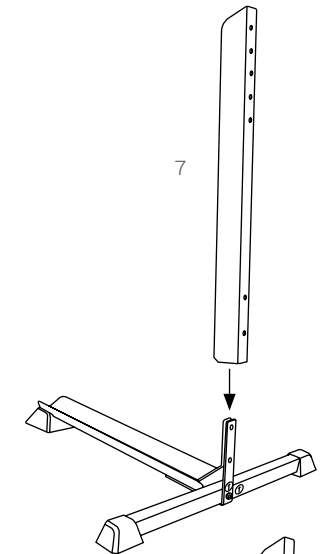

Place Bolts into each of the remaining two holes in the L-Piece. Place a Nut and Washer on the protruding Bolt end and tighten using the Allen Key and Socket Wrench

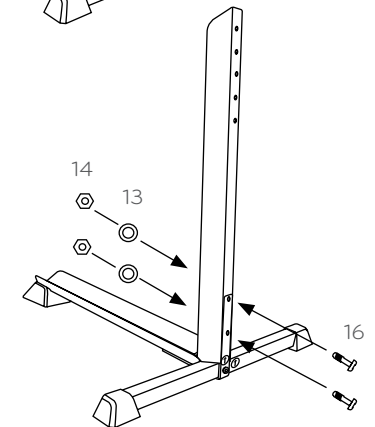

The Upright should now be securely connected to the Cross Bar

5

STEP 4

Connect the Adjustable Upright to the Upright

- 8. Adjustable Upright
- 9. V-Slot
- 10. Adjustment Knob

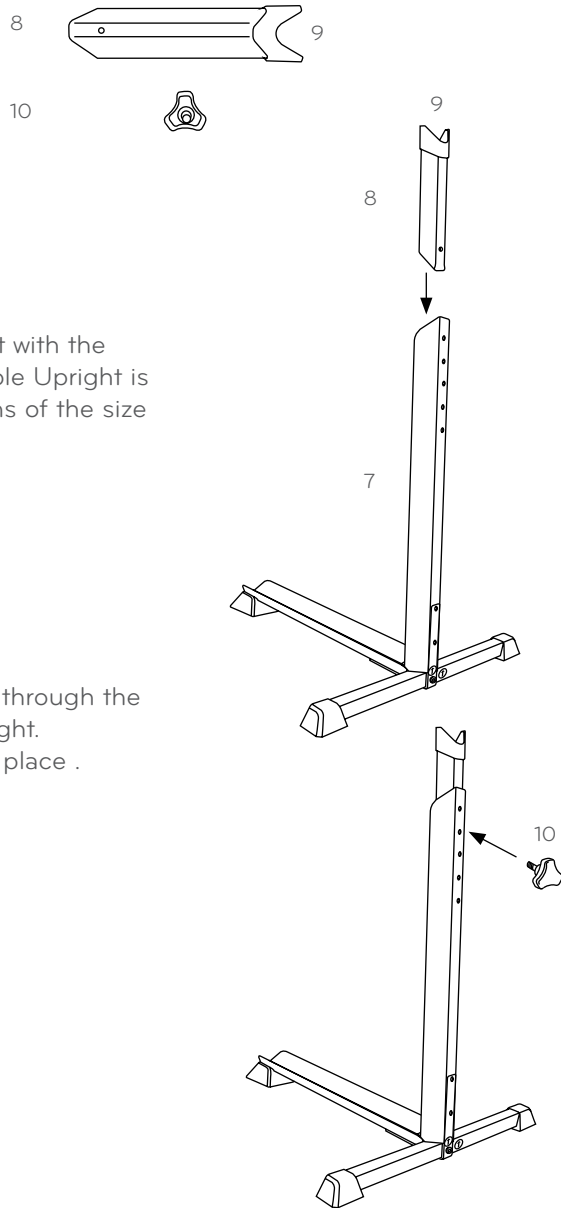

Align the Adjustable Upright with the Upright so that the Adjustable Upright is at the desired height in terms of the size of your bicycle.

Place the Adjustment Knob through the holes in the Adjustable Upright. Secure Adjustment Knob in place .

6

STORING YOUR BICYCLE

Position the back wheel of the bicycle facing the Bike Nook™

Roll the back wheel of the bicycle over the Ramp onto the Track until the wheel engages with the Upright. This is the horizontal storage position

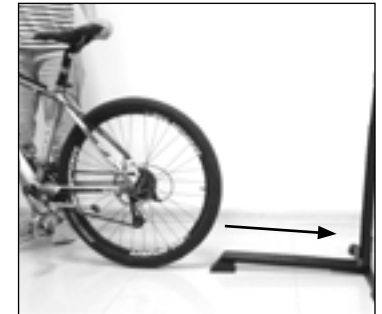

To store the bicycle in the vertical position, lift the front wheel upwards



Lower the seat holder onto the "V" of the Adjustment Upright.

Important: Ensure that the bicycle rests securely into the V-Slot and is stable. If not, return the bicycle to the horizontal position and lower (or raise) the Adjustment Upright

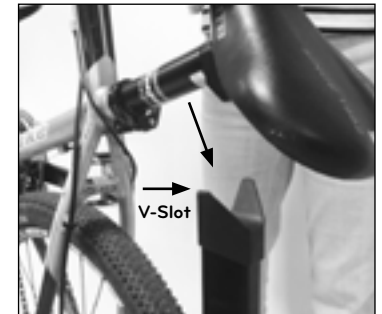

Use the Strap to secure the front wheel in place

When storing the bicycle in the vertical position, ensure that the V-Slot is at a height so that the weight (and centre of gravity) of the bicycle "leans" towards the Upright – not towards the Ramp

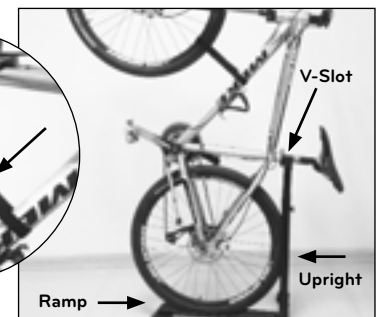

7



Distributed by:

Thane USA, Inc., Canton OH 44718, U.S.A.

Thane Canada Inc., Mississauga ON L4W 5M6, Canada

Thane Direct UK Ltd, London EC1Y 8NA, UK

Danoz Direct Pty Ltd, Alexandria NSW 2015, Australia

Operadora Ainoa, S.A.P.I. DE C.V., Ejercito Nacional 423-1 C.P 11520, México. D.F.

TVINS. 211 18 Malmö, Sweden

© 2017 Thane IP Limited.
MADE IN CHINA

"Thane", "Bike Nook", and related logos and variations are trademarks or registered trademarks, in Canada and/or other countries, of Thane IP Limited and/or its affiliated companies.